

GATE IB645 BRONZE

125 lb. SWP-200 lb. WOG† • General Service
Solid Wedge Disc • Non-Rising Stem
Threaded Bonnet • Gland Packed • Threaded Ends

4" size has split wedge and bolted bonnet. It is not covered in MSS SP-80.

SPECIFICATIONS

IB645	Conforms to: MSS SP-80. Type 1, Class 125, Threaded Ends.
-------	--

MATERIAL LIST

NO.	PART	MATERIAL	SPECIFICATION
1	Body	Bronze	ASTM B 62
2	Bonnet	Bronze	ASTM B 62
3	Wedge	Bronze	ASTM B 62
4	Stem	Bronze	ASTM B 62
5	Stuff Nut	Brass	ASTM B 283 C37700
6	Check Nut	Brass	ASTM B 283 C37700
7 ¹	Gland	Brass	ASTM B 124 C37700
8	Wheel Nut	Brass	Commercial
9	Handwheel	Mall. Iron	Commercial
10	Packing	Non-Asbestos	
11	Name Plate	Sh. Alum.	Commercial

¹ Not used on 1/2" and smaller.

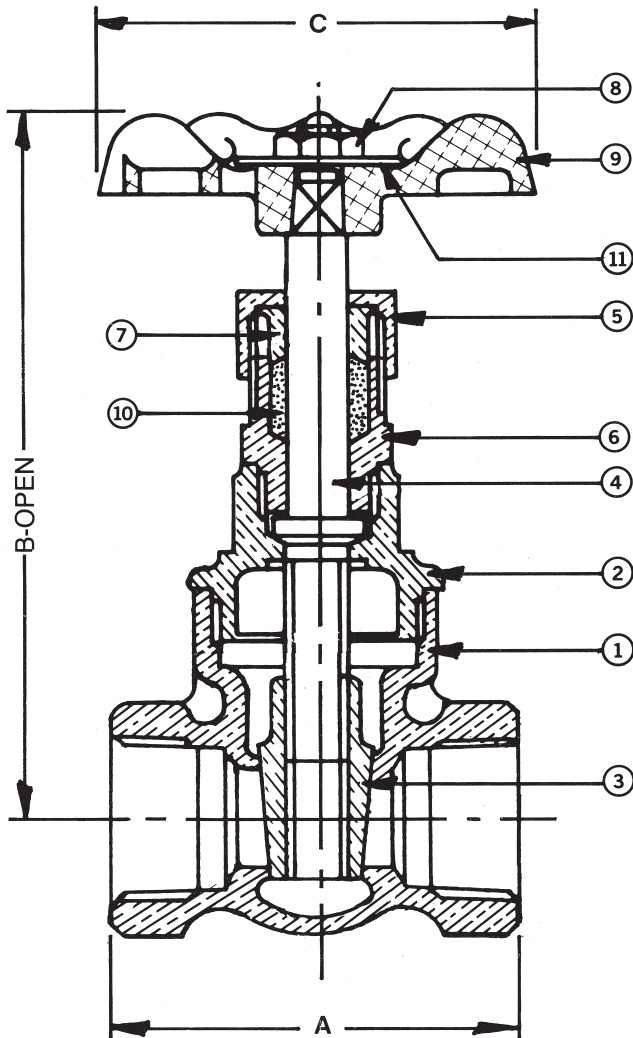

DIMENSIONS - INCHES / MILLIMETERS

Units	Size	A	B	C	C _v
Inches	1/4	1.75	3.63	2.00	5.6
mm	6.35	44.45	92.08	50.80	
Inches	3/8	1.81	3.63	2.00	10.7
mm	9.53	46.05	92.08	50.80	
Inches	1/2	2.00	3.63	2.00	1.8
mm	12.70	50.80	92.08	50.80	
Inches	3/4	2.13	4.38	2.50	32.0
mm	19.05	53.98	111.13	63.50	
Inches	1	2.56	5.00	2.75	54.0
mm	25.40	65.10	127.00	69.85	
Inches	1 1/4	2.78	5.31	3.13	97.0
mm	31.75	70.64	134.95	79.38	
Inches	1 1/2	2.81	6.34	3.50	135.0
mm	38.10	71.45	161.13	88.90	
Inches	2	3.31	7.44	3.75	230.0
mm	50.80	84.15	188.93	95.25	
Inches	2 1/2	4.19	9.13	4.75	337.0
mm	63.50	106.38	231.78	120.65	
Inches	3	4.63	10.47	5.25	536.0
mm	76.20	117.48	265.91	133.35	
Inches	4	5.50	15.50	5.25	960.0
mm	101.60	139.70	393.70	133.35	

† Non-Shock

Rev. 2

BETTER AT EVERY TURN



HAMMONDVALVE

www.hammondvalve.com

The information presented on this sheet is correct at the time of publication. Hammond Valve reserves the right to change design, and/or material specifications without notice. For the most current information access www.hammondvalve.com